

# PNEUMATIC SUCTION PUMPS PA



A newly designed range of ejectors has allowed creating this range of pneumatic suction pumps featuring an excellent ratio between the amount of consumed air and sucked air, as well as the ability to adjust the level of vacuum and flow rate according to the supply air pressure.

These pumps are powered with compressed air with a pressure ranging from 1 to 6 bar and they can produce a maximum vacuum of 90% and a suction flow rate between 15 and 320 m<sup>3</sup>/h, measured at a normal atmospheric pressure of 1013 mbar.

When designing these pumps, our attention was focused on noise. In fact, they are perfectly soundproofed and there are no moving parts subject to wear and vibrations. All this results in an extremely silent operation. Moreover, as they are based on the Venturi principle, they do not develop heat.

They are equipped as standard with a filter/pressure reducer unit for the supply air and a filter with microporous cartridge located on the suction inlet connection which can keep the finest dust and impurities. The excellent compressed air and sucked air filtration allows blowing air free from oil vapours, water condensation and impurities in the work environment, causing no pollution. The use of light alloys for making these pumps has allowed a considerable reduction of their weight thus allowing them to be directly installed onto the machine.

Thanks to their static operating principle, maintenance is reduced to a only a simple regular cleaning of the filters.



3D drawings are available on [vuototecnica.net](http://vuototecnica.net)

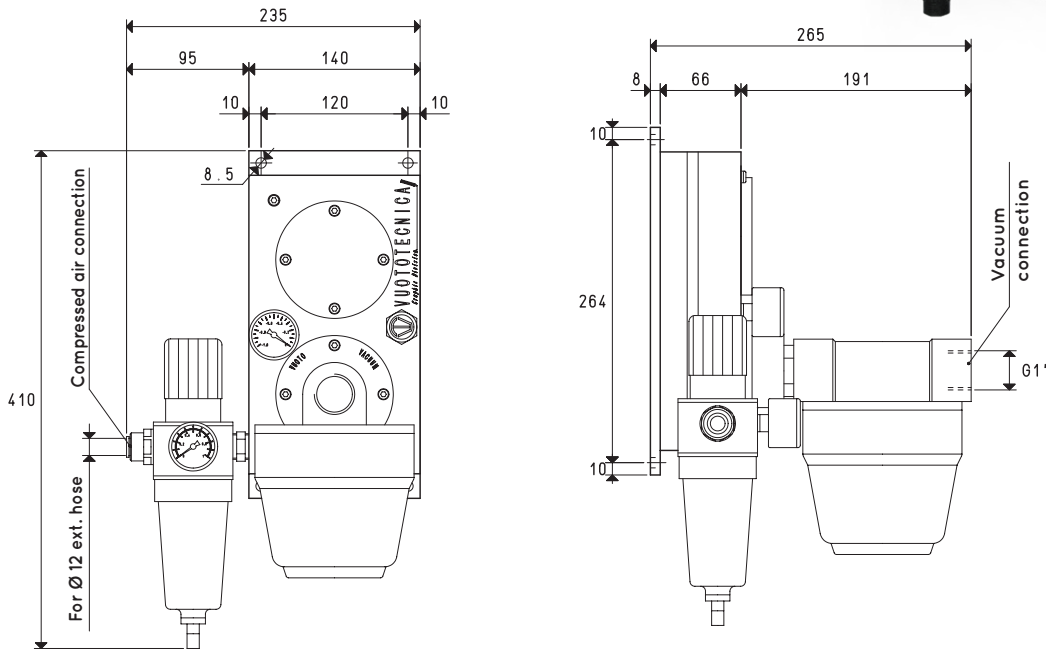

Item		PA40					
Supply pressure	bar	1	2	3	4	5	6
Maximum level of vacuum	-KPa	14	30	46	65	82	90
Air consumption	NI/s	1.0	1.5	2.0	2.3	2.7	3.2
Intake air flow rate	m <sup>3</sup> /h	15	23	30	36	39	42
Weight	Kg	6.2					
Item		PA70					
Supply pressure	bar	1	2	3	4	5	6
Maximum level of vacuum	-KPa	14	30	46	65	82	90
Air consumption	NI/s	2.0	3.0	4.1	4.9	5.7	6.6
Intake air flow rate	m <sup>3</sup> /h	29	47	58	65	73	80
Weight	Kg	6.2					
Item		PA100					
Supply pressure	bar	1	2	3	4	5	6
Maximum level of vacuum	-KPa	11	28	45	65	82	90
Air consumption	NI/s	3.0	4.6	6.2	7.2	8.5	9.8
Intake air flow rate	m <sup>3</sup> /h	28	57	75	88	98	108
Weight	Kg	6.2					
Operating temperature	°C	-20 / +80					

NOTE: All vacuum values indicated in the table are valid at the normal atmospheric pressure of 1013 mbar and obtained with a constant supply pressure.

Vacuum generator supply must be carried out with non-lubricated compressed air, 5 micron filtration, in accordance with standard ISO 8573-1 class 4.

Transformation ratio: N (newton) = Kg x 9.81 (force of gravity)

inch =  $\frac{\text{mm}}{25.4}$  ; pounds =  $\frac{\text{g}}{453.6} = \frac{\text{Kg}}{0.4536}$

Adapters for GAS - NPT threading available on page 1.130